

Q-Vent Mezzo

Mechanical Ventilation with Heat Recovery

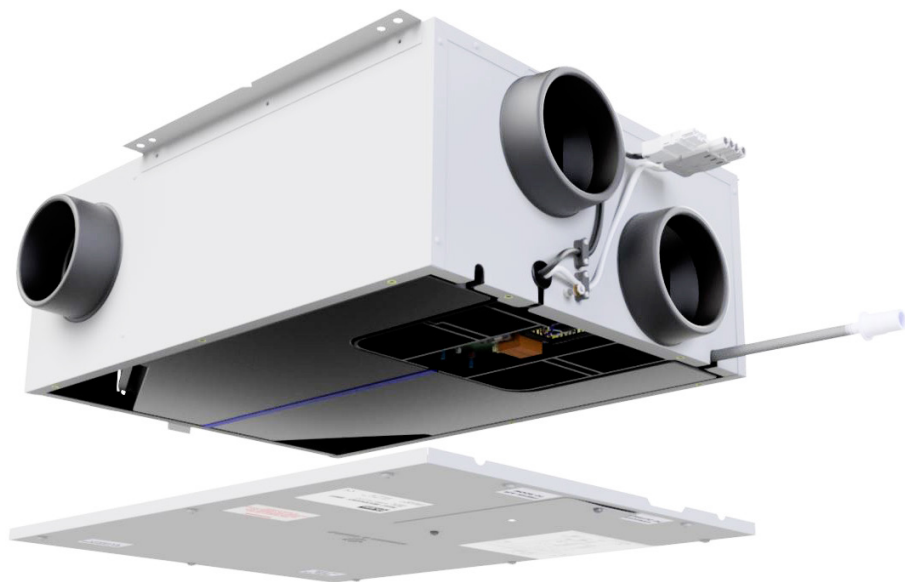

Components

1	Heat Exchanger	9	Real Time Clock (RTC)
2	100mm/125mm Ø Spigot	10	Commissioning Access Panel
3	Anti-Flood Sensor	11	Condensate Tray Assembly
4	Extract/Supply Fan	12	Printed Circuit Board (PCB)
5	Fixing Bracket	13	Gravity Condensate Overflow
6	Condensate Adapter	14	Front Cover Plate
7	Easy to Adjust Commissioning Panel	15	Integral Filter
8	Electrical Connections	16	Magnetic Filter Cover

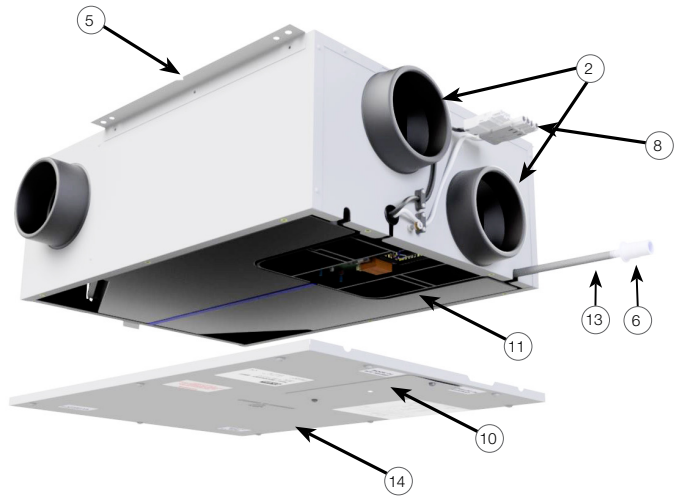

UPWARD ELEVATION (cutaway)

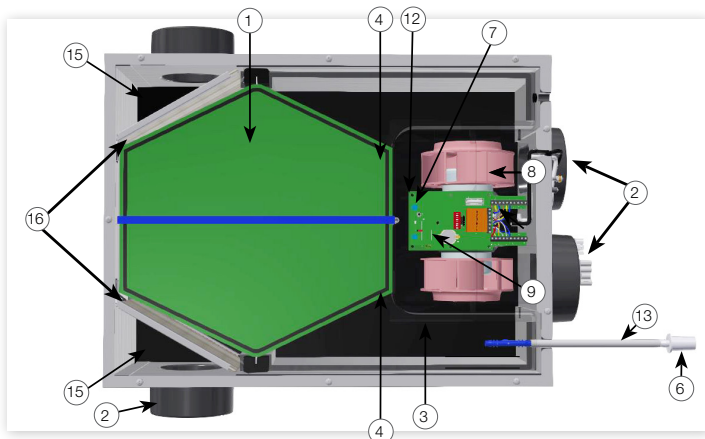

Product Code

Q-Vent Mezzo

Application	Specific Fan Power (W/l/s)	Heat Exchanger Efficiency
Kitchen + 1 wet room	0.72	88%
Kitchen + 2 wet rooms	0.83	85%
Kitchen + 3 wet rooms	1.02	83%
Kitchen + 4 wet rooms	1.27	81%

FEATURES & BENEFITS

- Removable Filters**
 Two inline filters incorporated within the unit.
- Sleep Mode**
 The unit incorporates a Real Time Clock which allows the unit to be configured to block boost demand between pre-set times
- Commissioning Panel**
 An improved installer friendly, easy to adjust, commissioning panel.
- Guarantee**
 The unit shall come with a 5 year guarantee which starts from the day of delivery, and includes parts and labour for the first year and parts only for the remaining 4 years.
- Heat Recovery Efficiency**
 Up to 95% through counterflow heat exchanger
- Pre-set Airflow Providing**
 8 l/s @ trickle rate
 24 l/s @ boost rate
- Condensate High Level Cut Off**
 Condensate sensors fitted as standard
- Fixing Bracket**
 Allows direct fixing to ceiling providing an in-build fall to condensate drain.
- Spigot Size Options**
 Connections can be 125mm Ø or 100mm Ø
- Electrical Supply**
 230v fused at 3 amp, easy access via electrical cover plate
- Delayed Boost**
 Two minute delay after bathroom light activation
- App Controlled Commissioning.**
- JS11 Switch**
 A filter service light, boost mode, purge mode and summer bypass incorporated into one switch.

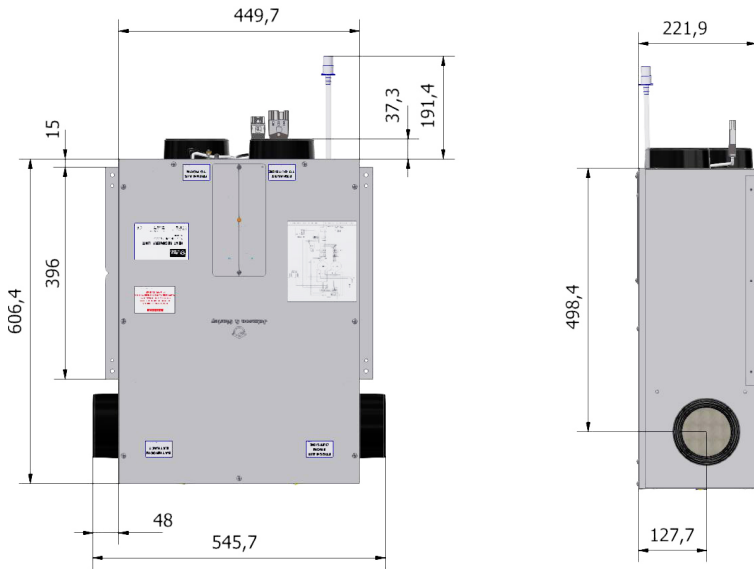

DIMENSIONS

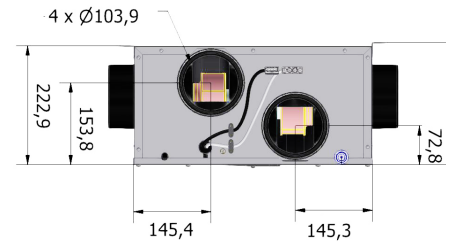

FAN PERFORMANCE

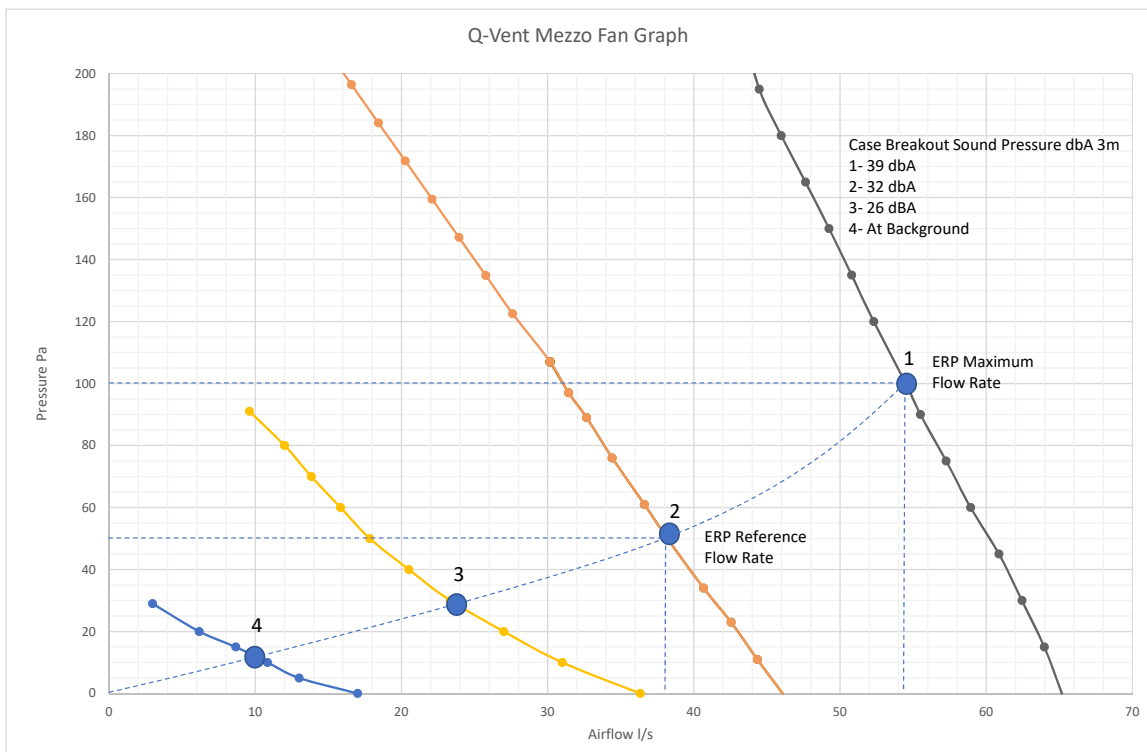

CONTACT DETAILS



sustainable solutions
under one roof

HEATING / HOT WATER / VENTILATION

Dravo

Combat[®]

Heating Solutions Ltd

Sales

Tel: 01604 762881

email: sales@johnsonandstarley.co.uk

Customer Services

Tel: 01604 762881

email: cs@johnsonandstarley.co.uk

Technical

Tel: 01604 762881

email: service@johnsonandstarley.co.uk

Sales

Tel: 01604 707022

email: sales@dravo.co.uk

Customer Service

Tel: 01604 707022

email: info@dravo.co.uk

Technical / Service

Tel: 01604 707023

email: service@dravo.co.uk

Sales

Tel: 0121 506 7700

email: uksales@combat.co.uk

Customer Service

Tel: 0121 506 7700

email: uksales@combat.co.uk

Technical / Service

Tel: 0121 506 7700

email: ukservice@combat.co.uk

In the interest of continuous development Johnson & Starley reserve the right to change specification without prior notice.



Johnson & Starley Ltd
Rhosili Road, Brackmills
Northampton
NN4 7LZ
01604 762881